

A4

流程：鋸料>鍛造>T4/T6>切邊>CNC加工>研磨>震動>洗白>品管>包裝

檢驗標準

	尺寸公差
Q1	62.5±0.15

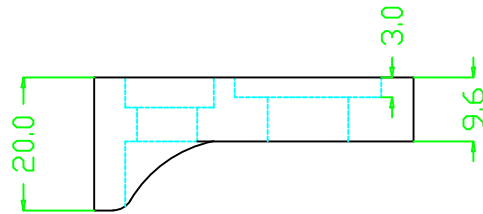
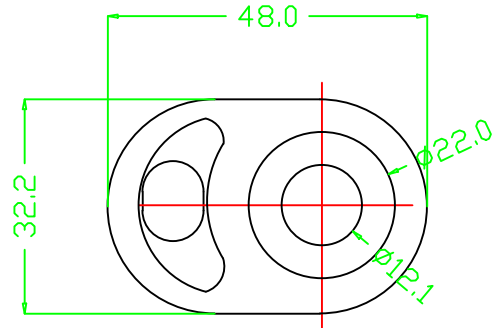

鍛造用料:  $\phi?? \times ??$  mm  
 PS: 鋁料一米長可切 ?? Piece

IP13BKS0008A

繪圖 Drawn	Carlson	2013-12-16	處理 FINISH		
校對 Checked		材質 Material	AL6061	比例 Scale	1:1
審核 Approved		產品名稱 Product	避震取付	單位 Unit	mm
		製圖編號 Drawing No.	JD-90-233-3	版本 Version	V1
		客戶編號 Customer No.	朗安	角度公差 ANGULAR	±0.5°



將頂科技

AUTODESK

AUTODESK