

A4

流程：鋸料>鍛造>T4/T6>切邊>CNC加工>研磨>震動>洗白>品管>包裝

| | |
|------|-----------|
| 檢驗標準 | |
| | 尺寸公差 |
| Q1 | 62.5±0.15 |

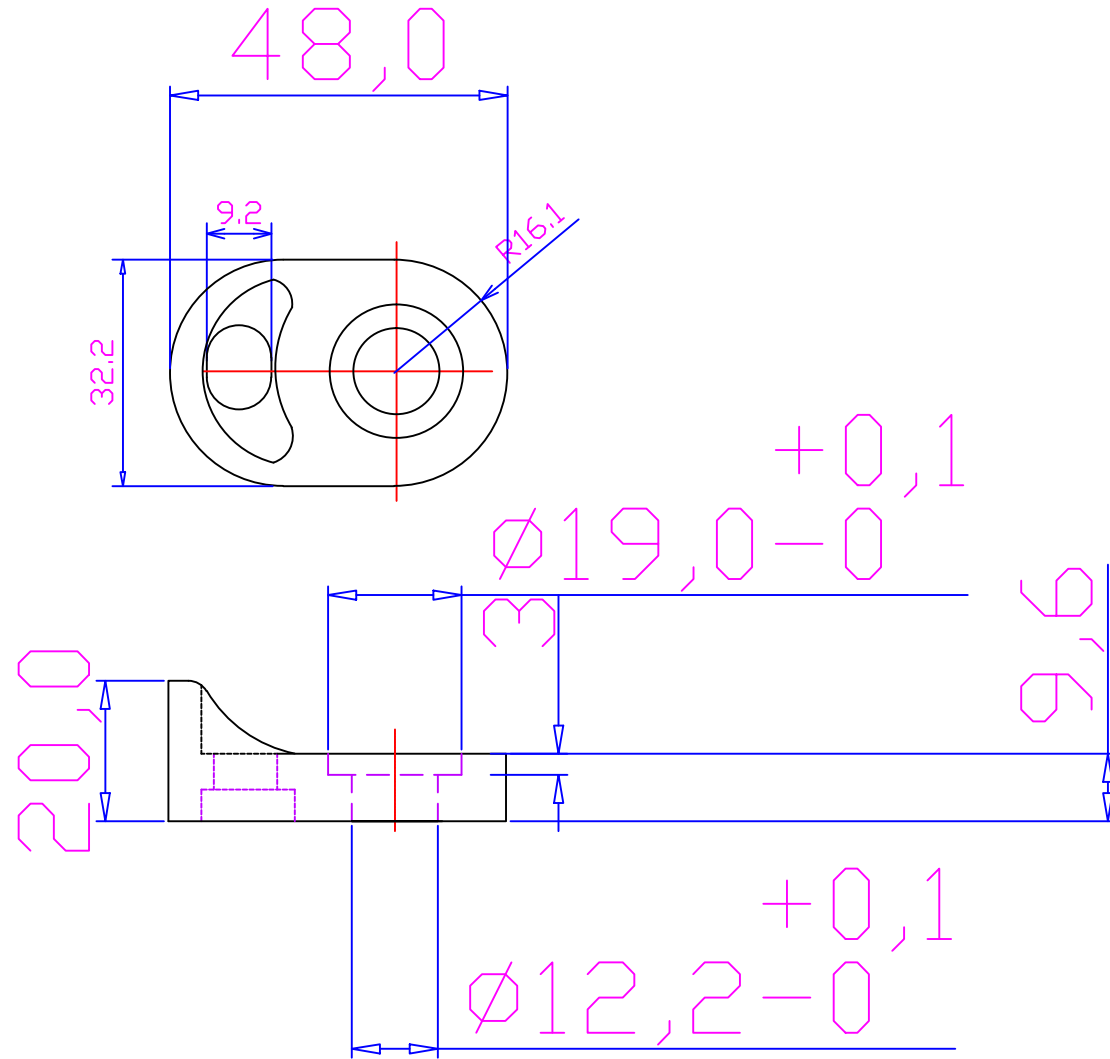

鍛造用料: $\phi?? \times ??$ mm
 PS: 鋁料一米長可切 ?? Piece

IP13BKS0008A

| | | | | | | | |
|----------------|---------|----------------------|--------------|---------------|-----|-----------------|-------|
| 繪圖 Drawn | Carlson | 2013-12-16 | 處理 FINISH | | | | |
| 校對 Checked | | 材質 Material | AL6061 | 比例 Scale | 1:1 | 公差 TOLERANCE | |
| 審核 Approved | | 產品名稱 Product | 避震取付 | 單位 Unit | mm | >1-4 | ±0.1 |
| | | 製圖編號 Drawing No. | JD-9Q-233-2 | 版次 Version | | >4-16 | ±0.2 |
| | | 客戶編號 Customer No. | 朗安 | | | >16-63 | ±0.3 |
| | | | | | | >63-250 | ±0.5 |
| | | | | | | 角部公差 ANGULAR | ±0.5° |

