

A4

流程：下料>鍛造>T4/T6>切邊>CNC加工>研磨>震動>洗白>品管>包裝

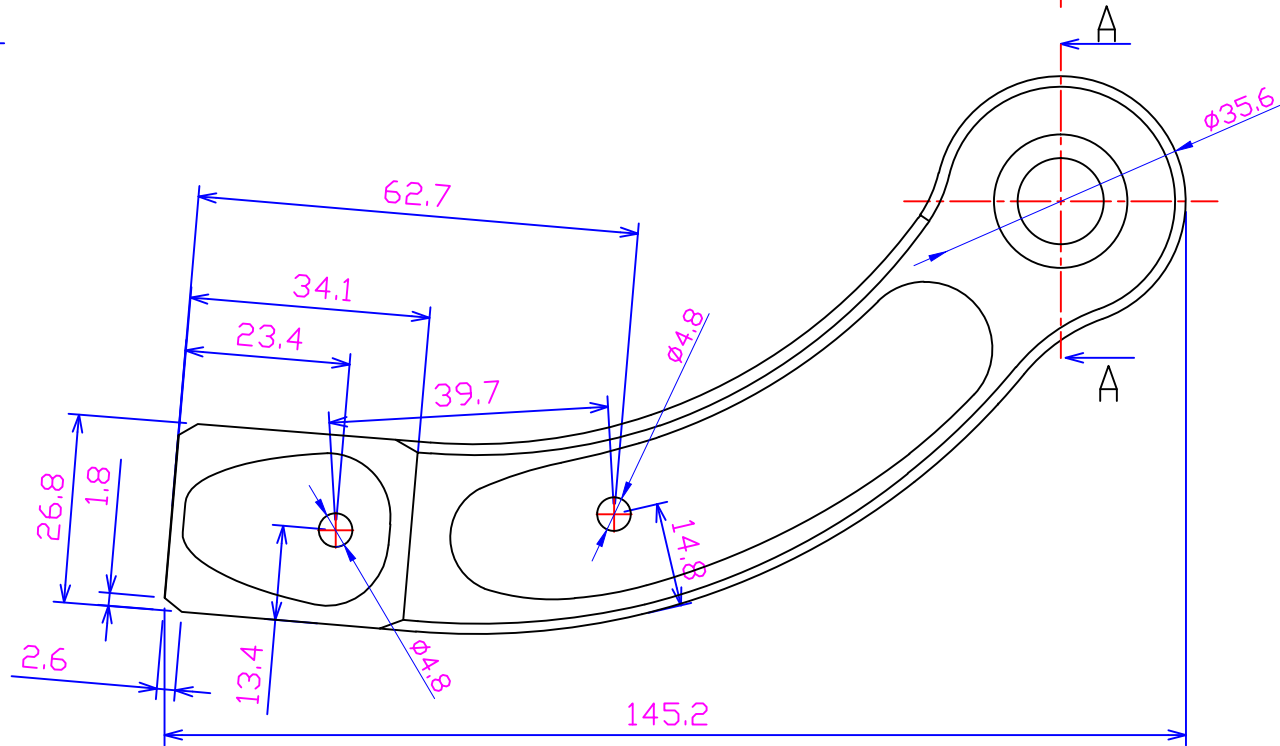
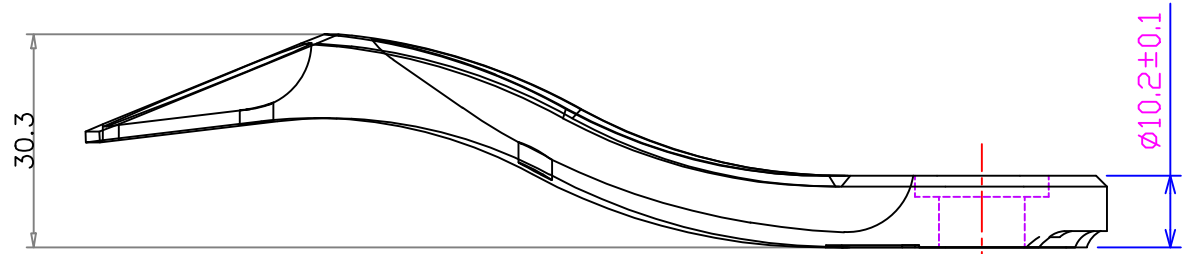
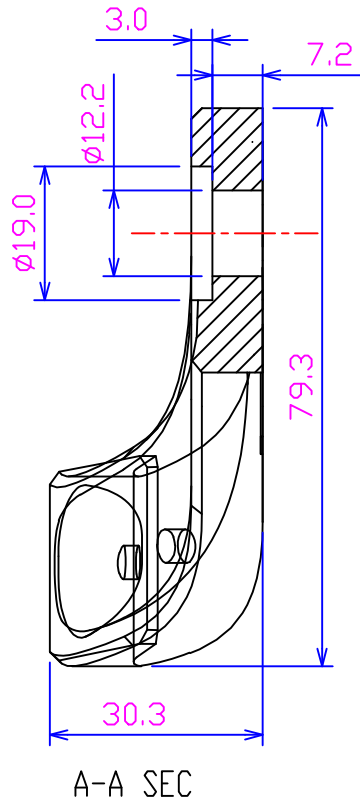

鍛造用料: $\phi?? \times ??$ mm
 PS: 鋁料一米長可切 ?? Piece

IP13BKS0007A

繪圖 Drawn	Carlson	2013-12-16	處理 FINISH		
校對 Checked		材質 Material	AL6061	比例 Scale	1:1
審核 Approved		產品名稱 Product	避震取付	單位 Unit	mm
		製圖編號 Drawing No.	JD-9Q-0184-4	版本 Version	>16-63 ±0.3
		客戶編號 Customer No.	朗安		>63-250 ±0.5
					角部公差 ANGULAR ±0.5°

AUTODESK

AUTODESK