

工艺流程: 落料→锻造→切边→冲孔→钻孔→铣角→研磨→振动→漂白→全检→包装出货

检验标准

检验项目	尺寸公差
Q1	10.0±0.2
Q2	8.0±0.1
Q3	51.0±0.1
Q4	18.0±0.1

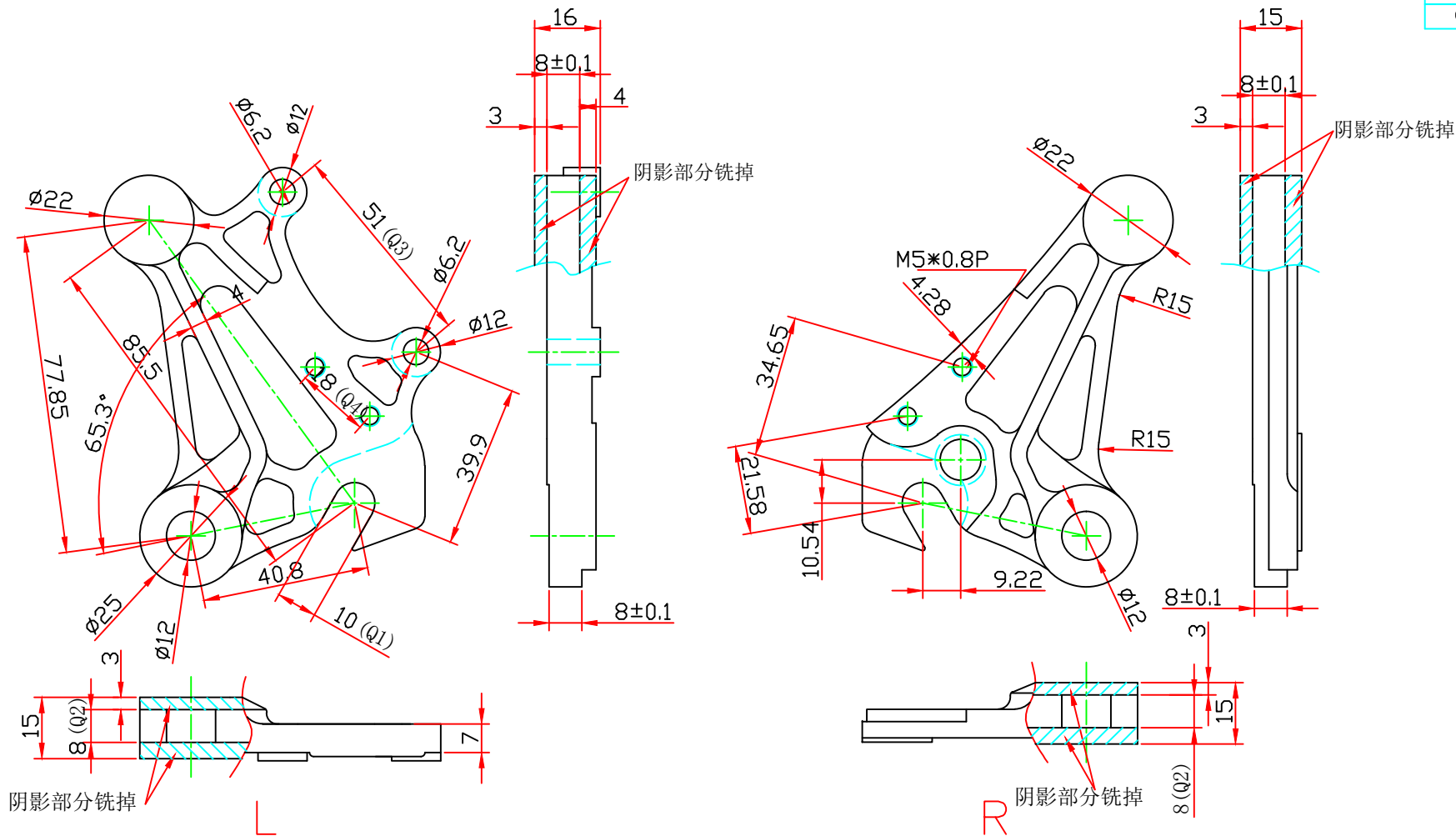

PRODUCT 品名:	勾爪	UNIT 单位:	mm	绘图: DRAWN BY	杨华	06.01.07	表面处理	依客户	硬度	INDENTATION		SIGN	REVISION	DATE	DESCRIPTION
RAWING NO	9F-0058F	SCALE 比例:	1:1.5	审核: CHECKED BY								1			
CLIENT 客户:	永祺 EM6506	MASTERIAL 材质:	6061	批准: APPROVED BY								2			
将顶科技(深圳)有限公司 JIANGDING,HANDWARE.MANUFACTURE.CO.LTD											3				