

注: 未注尺寸依电脑图档, 详细参照3D图, 以标注为准

重点检验

??	尺寸公差
Q1	10.0 ^{+0.2} ₀
Q2	51.0±0.1
Q3	M5XP0.8
Q4	20.0±0.1

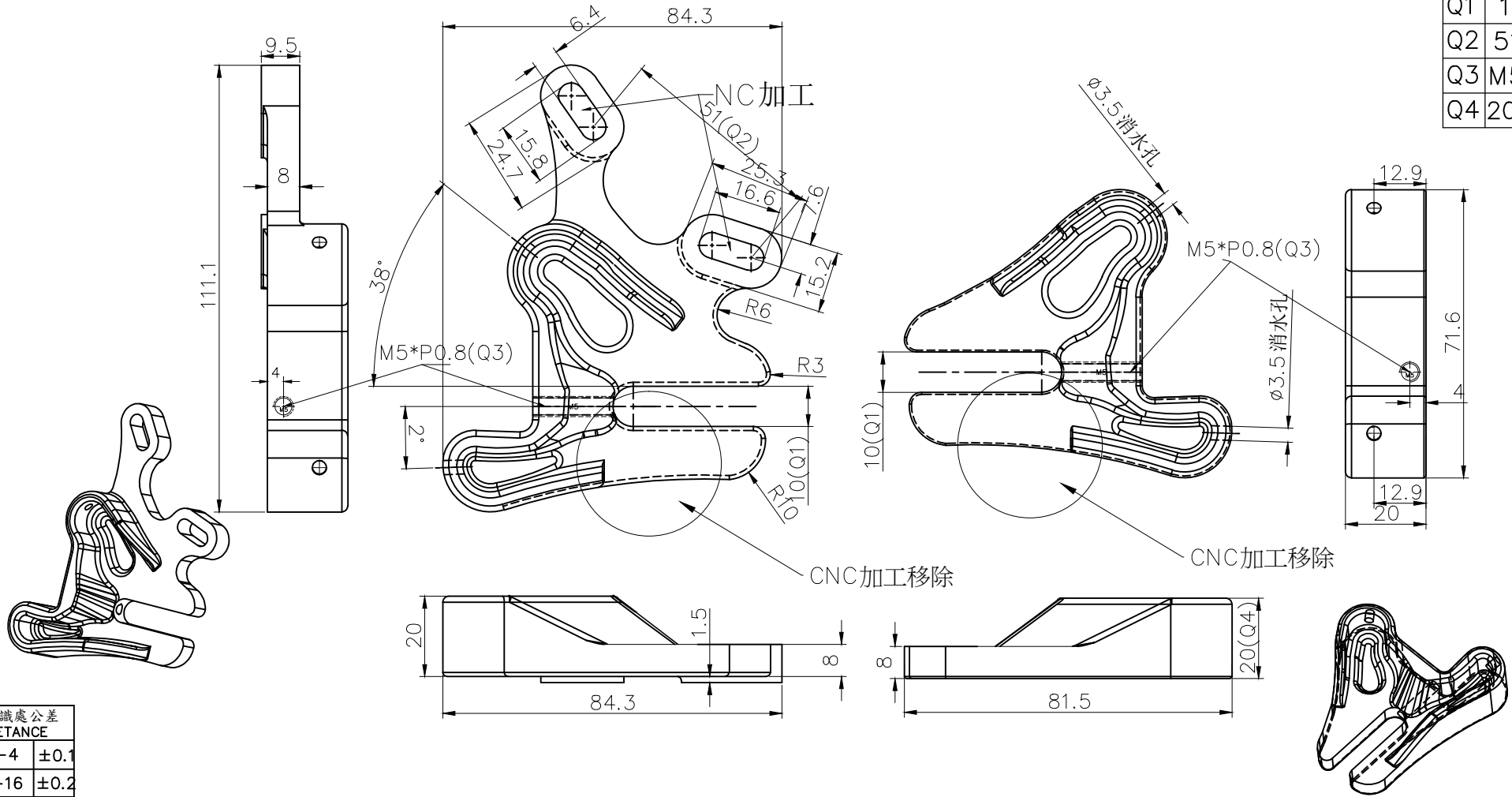

未注識處公差 TOLERANCE	
>1-4	±0.1
>4-16	±0.2
>16-63	±0.3
>63-250	±0.5
角度公差 ANGULAR	
	±0.5°

PRODUCT ???	UNIT ???	MM	DRAWN BY 趙先雲	09.08.28	??	INDENTATION	?? ? 1? ???	⊕	△			
RAWING NO ?????	JD-9F-0264-1	SCALE 1:1	CHECKED BY ???			???? (??)????			△			
CLIENT ???	???	MASTER ???	APPROVED BY ???			JIANGDING,HANDWARE.MANUFACTURE CO.,LTD			△			
									SIGN	REVISION	DATE	DESCRIPTION