

文件编号 JD-PJ-0296 ?? A0

注:未注尺寸依电脑图档,详细依3D图,以标注为准

重点检验	
??	尺寸公差
Q1	10.0 <sup>+0.2</sup> <sub>-0.1</sub>
Q2	6.5 <sup>+0.1</sup> <sub>-0.0</sub>
Q3	24.0 <sup>+0.15</sup> <sub>-0.0</sub>
Q4	M6XP1.0

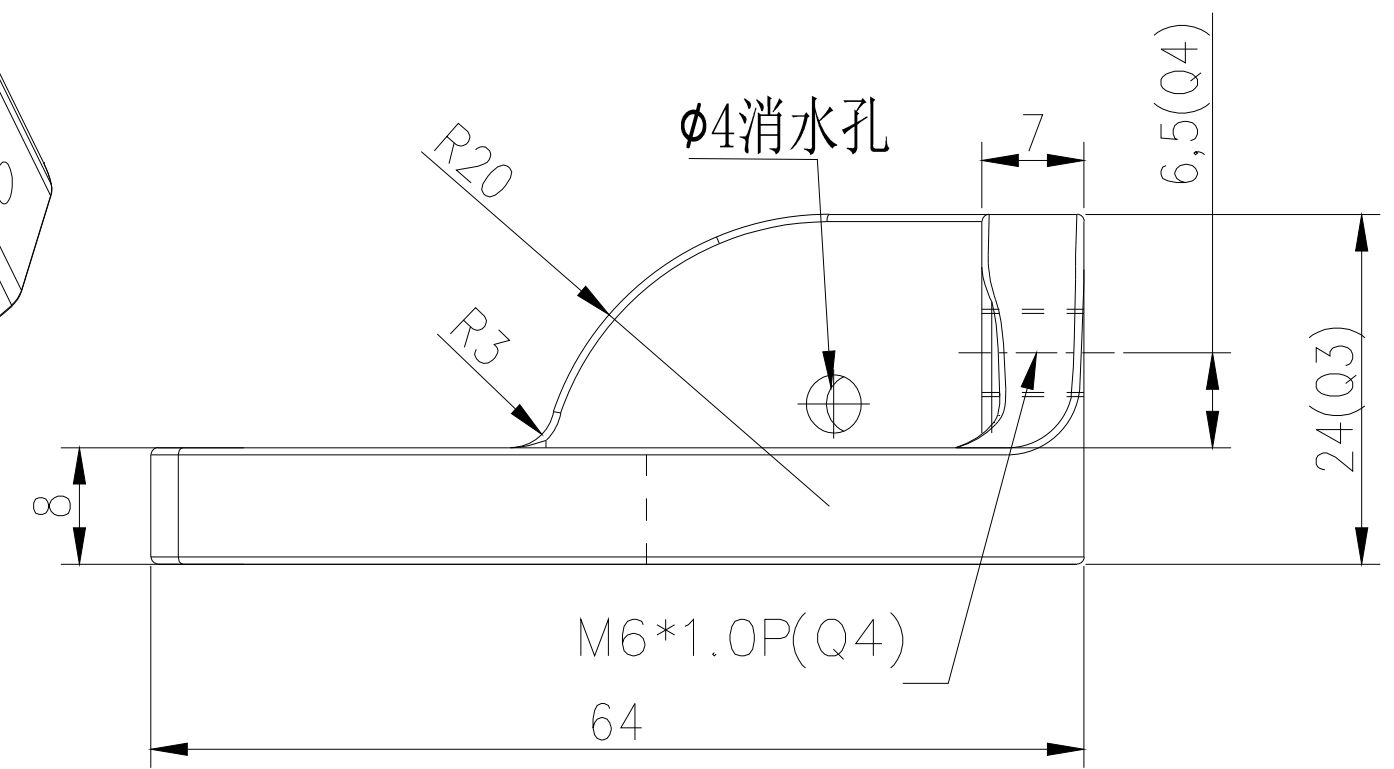
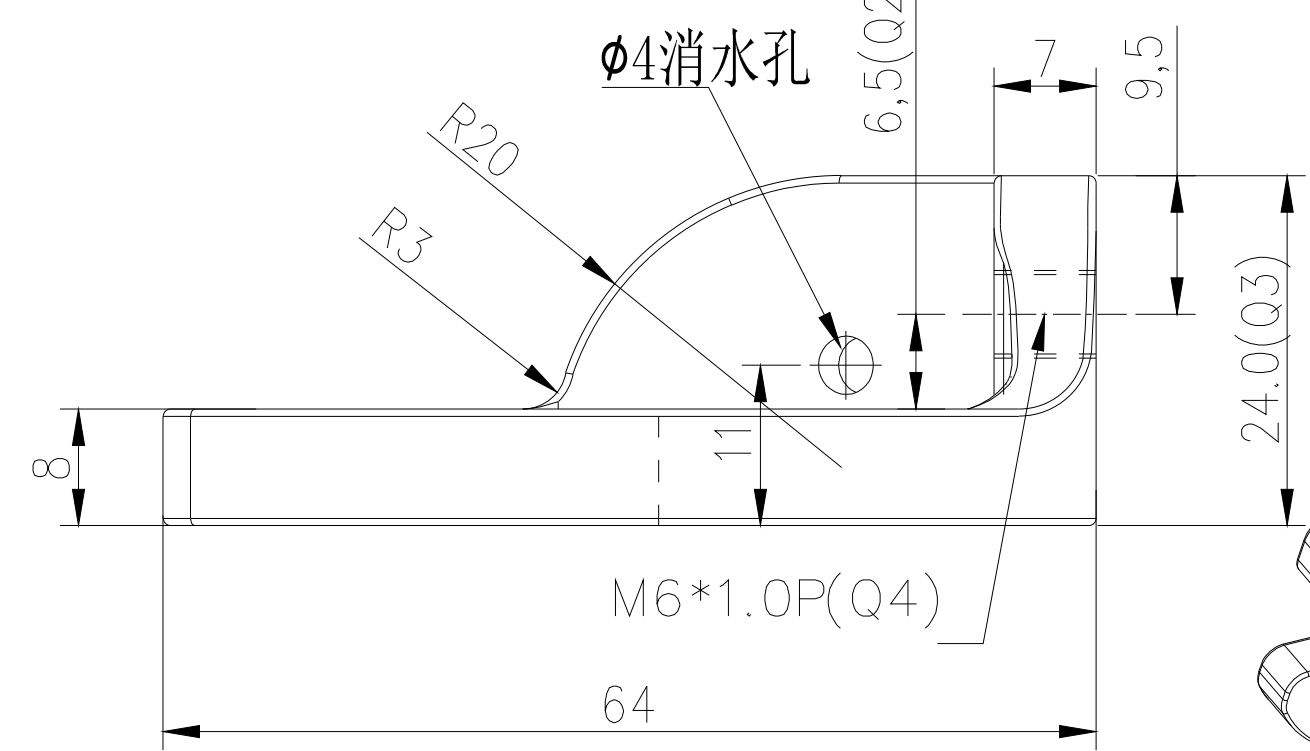
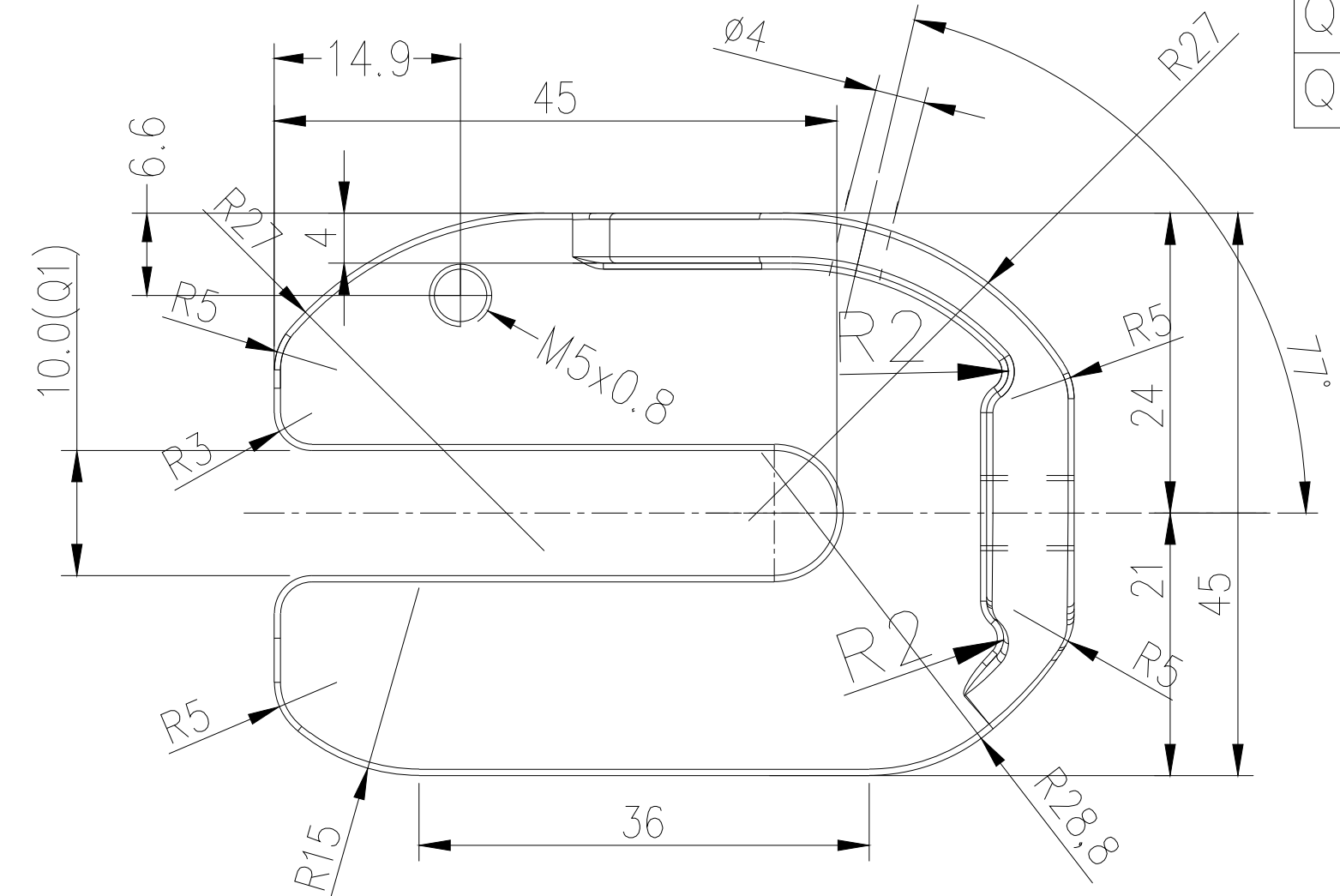
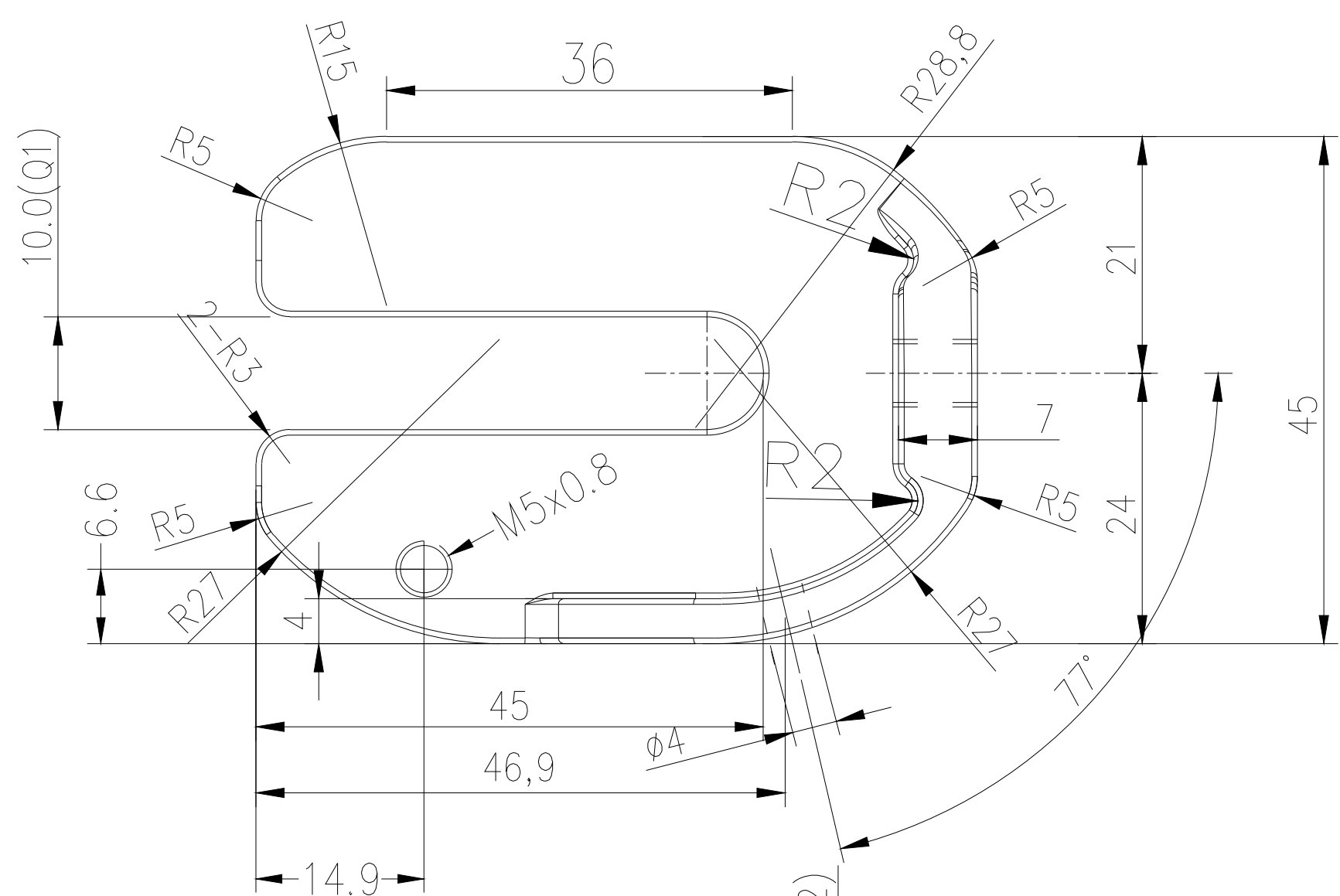

右勾爪

左勾爪

GB/T1804???	???
120↑	±0.5
30~120	±0.3
6~30	±0.2
6↓	±0.1
??	0.5°

PRODUCT ???	UNIT MM	DRAWN BY ???	09.07.0	INDENTATION ???	HRB52	???	???	???	???	???	???	???	???	???	???	???	???	???	???	???
RAWING NO JD-9F-0263-1	SCALE 1:1	CHECKED BY ???																		
CLIENT IO-ND-189	MASTERIA ???	APPROVED BY ???																		

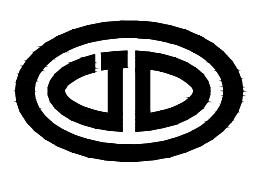

JIANGDING, HANDWARE MANUFACTURE CO., LTD

SIGN REVS ION DATE DESCRIPTION