

注：不得依图形量测，应依标注数据为准。

重点检验	
项目	尺寸公差
Q1	9.0 <sup>+0.2</sup> <sub>-0.05</sub>
Q2	18.0±0.1
Q3	12.3 <sup>+0.15</sup> <sub>-0.1</sub>
Q4	23.8±0.15
Q5	0.15 <sup>+0.05</sup> <sub>0</sub>
Q6	∅22 <sup>+0.0</sup> <sub>-0.2</sub>
Q7	74.2±0.1
Q8	0.94±0.1
Q9	6.8±0.1
Q10	55.9±0.1
Q11	10.7±0.1
Q12	24.3±0.1

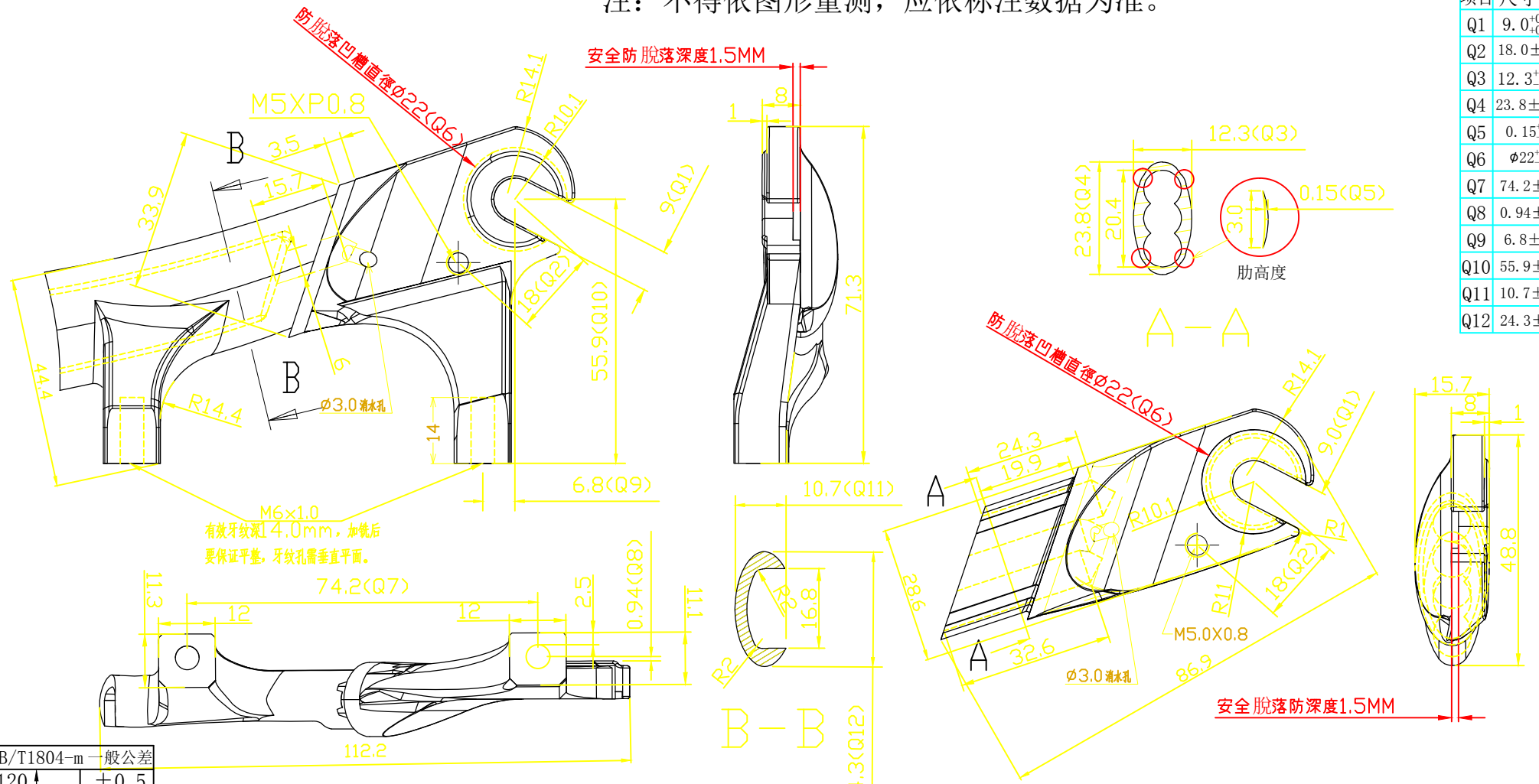

左 右

GB/T1804-m 一般公差	
120↑	±0.5
30~120	±0.3
6~30	±0.2
6↓	±0.1
角度	0.5°

PRODUCT	?? ?	UNIT	MM	DRAWN BY	10.07.21	INDENTATION	HRB52	?? ? 1 ? ???	⊙	△			
RAWING NO	JD-9E-0048	SCALE	1:1	CHECKED BY			???? (??)????			△			
CLIENT	?? 23-G208-1	MASTER	Ab?	APPROVED BY			JIANGDING,HANDWARE.MANUFACTURE.CO.LTD			△			
										SIGN	MODIFY	DATE	DESCRIPTION