

文件编号 JD-PJ-0421 ?? A0

注：右边共用9E-0039右边，详细请参照3D。

| 重点检验 | |
|------|---------------------------------------|
| 项目 | 尺寸公差 |
| Q1 | 10.0 ^{+0.2} _{-0.0} |
| Q2 | 15.0 ^{+0.0} _{-0.1} |
| Q3 | 11.6 ^{+0.0} _{-0.1} |
| Q4 | φ15.0 ^{+0.0} _{-0.1} |

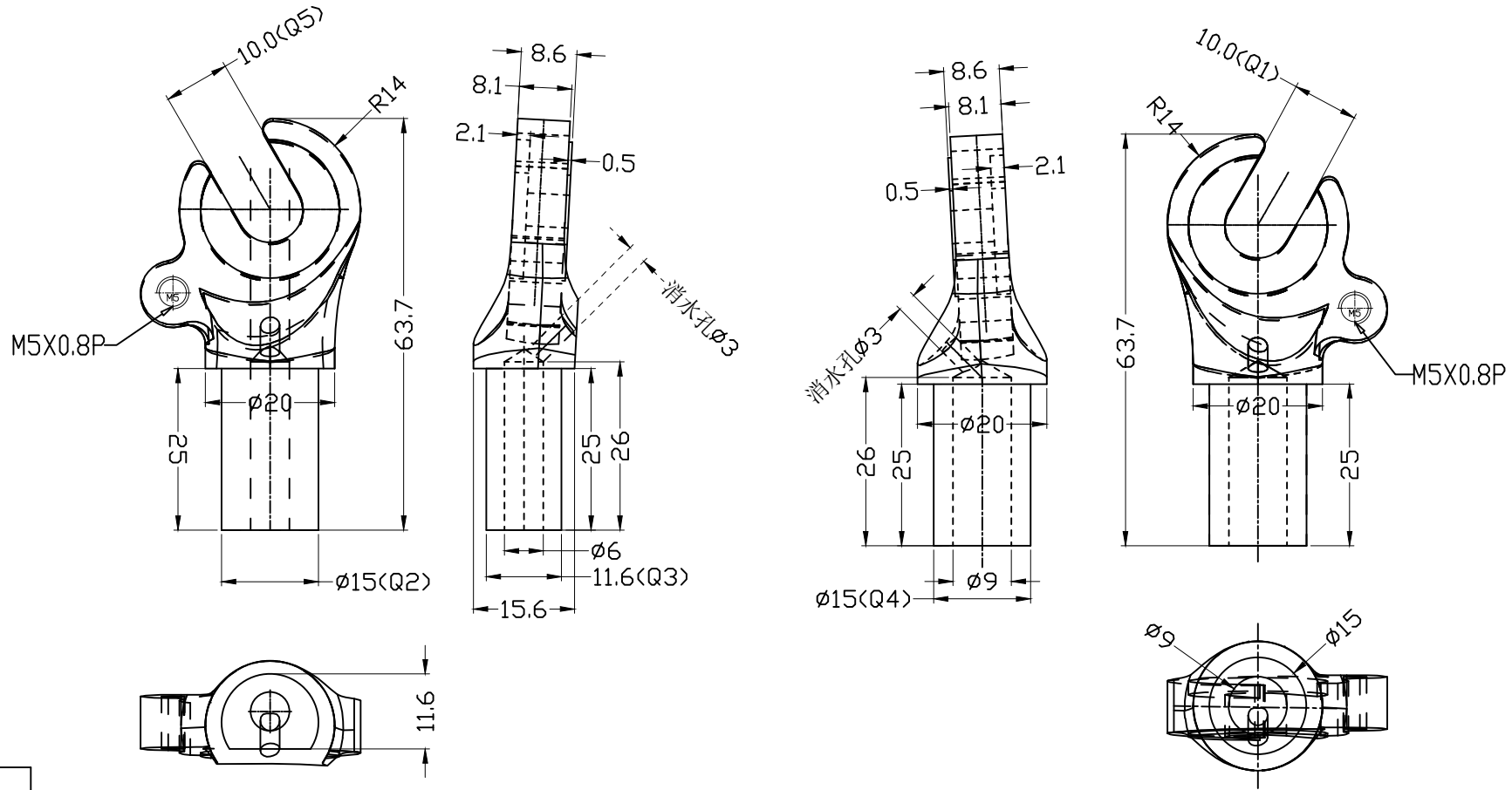

| ???? | |
|--------|-------|
| 50~120 | ±0.25 |
| 30~50 | ±0.2 |
| 10~30 | ±0.15 |
| 10↓ | ±0.1 |
| ?? | 0.5° |

| | | | | | | | | | | | | | | |
|-------------------------|---------------|-----|-----------------|----------|-------------|--|------|------|-----|---|------|----------|------|-------------|
| PRODUCT ??? | UNIT ??? | MM | DRAWN BY 趙先雲 | 09.12.17 | ?? | HRB52 | ?? | 1? | ??? | ⊕ | △ | | | |
| RAWING NO JD-9E-0040 | SCALE 1:1 | | CHECKED BY | | INDENTATION | ???? | (??) | ???? | | △ | | | | |
| CLIENT 10-ND-236 | MASTER ??? | APP | APPROVED BY | | | JIANGDING,HANDWARE.MANUFACTURE CO.,LTD | | | | △ | | | | |
| | | | | | | | | | | | SIGN | REVISION | DATE | DESCRIPTION |