

注1. 未注尺寸依电脑图档, 详细依3D图
 2. 不得依图面量测尺寸, 以标注为准, 开槽NC加工

重点检验	
??	尺寸公差
Q1	9.1 ^{+0.1} ₋₀
Q2	17.02 ⁺⁰ _{-0.1}
Q3	15.9 ⁺⁰ _{-0.1}
Q4	7.2±0.1
Q5	M5XP0.8

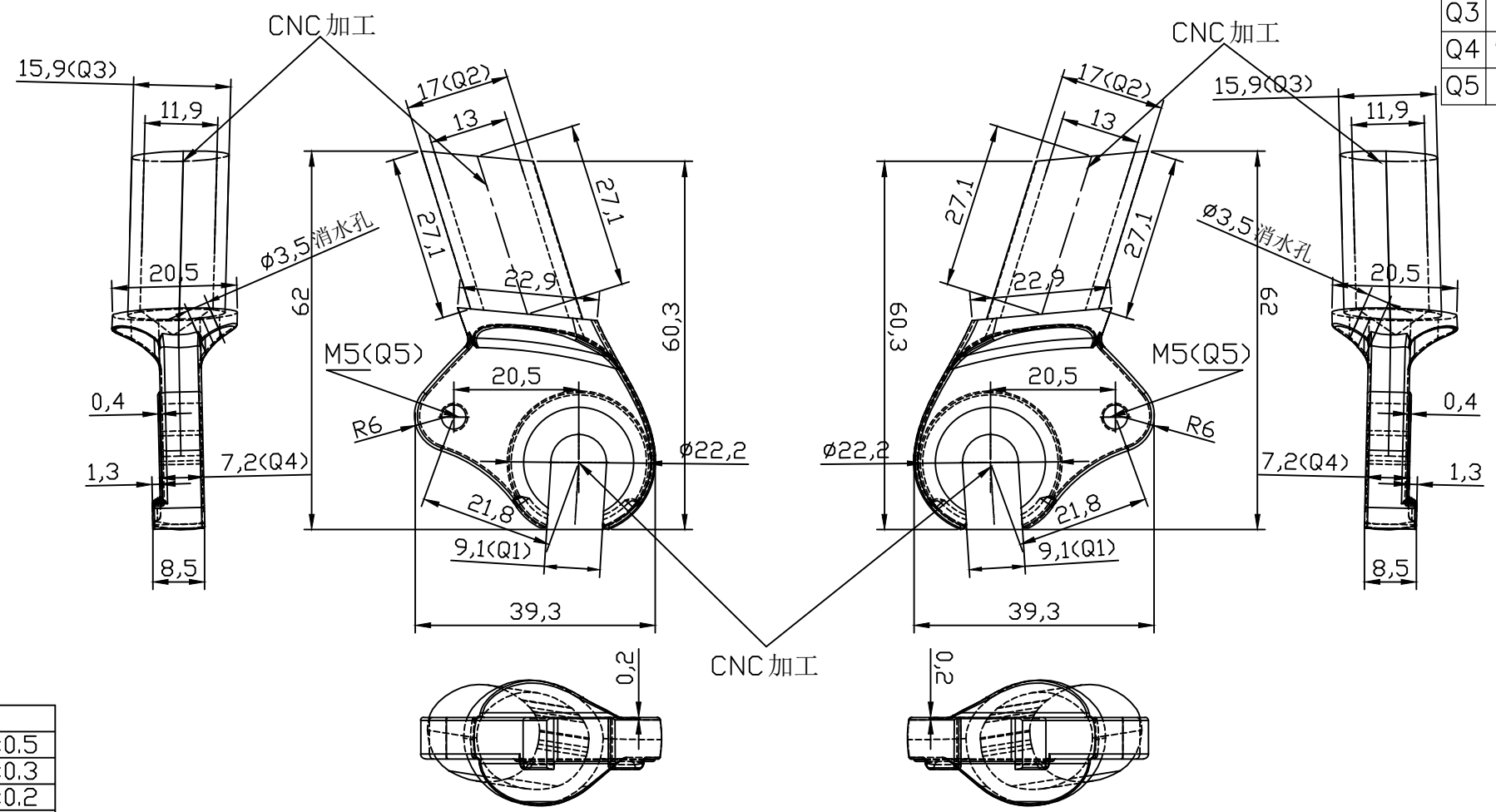

????	
64~120	±0.5
16~64	±0.3
4~16	±0.2
	±0.1
??	0.5°

收到此图, 前图09.06.25作废

PRODUCT ???	前叉勾爪	UNIT ???	MM	DRAWN BY ???	09.07.01	??	INDENTATION	?? ? 3? ???	⊕	△				
RAWING ?????	NO JD-9E-0053	SCALE ???	1:1	CHECKED BY ???			???? (??)????			△				
CLIENT ???	爱地雅 ID-ND-213-2	MASTER ???	Ab?	APPROVED BY ???			JIANGDING,HANDWARE.MANUFACTURE CO.,LTD			△				
											SIGN	REVISION	DATE	DESCRIPTION