

注: 未注尺寸依电脑图档  
不得依图面量测尺寸

重点检验	
??	尺寸公差
Q1	10.0 <sup>+0.2</sup> <sub>-0.0</sub>
Q2	25.4±0.1
Q3	26.1±0.2
Q4	22.5 <sup>+0.0</sup> <sub>-0.1</sub>
Q5	13.6±0.2
Q6	10.1 <sup>+0.0</sup> <sub>-0.2</sub>
Q7	M5XP0.8
Q8	6.5±0.1

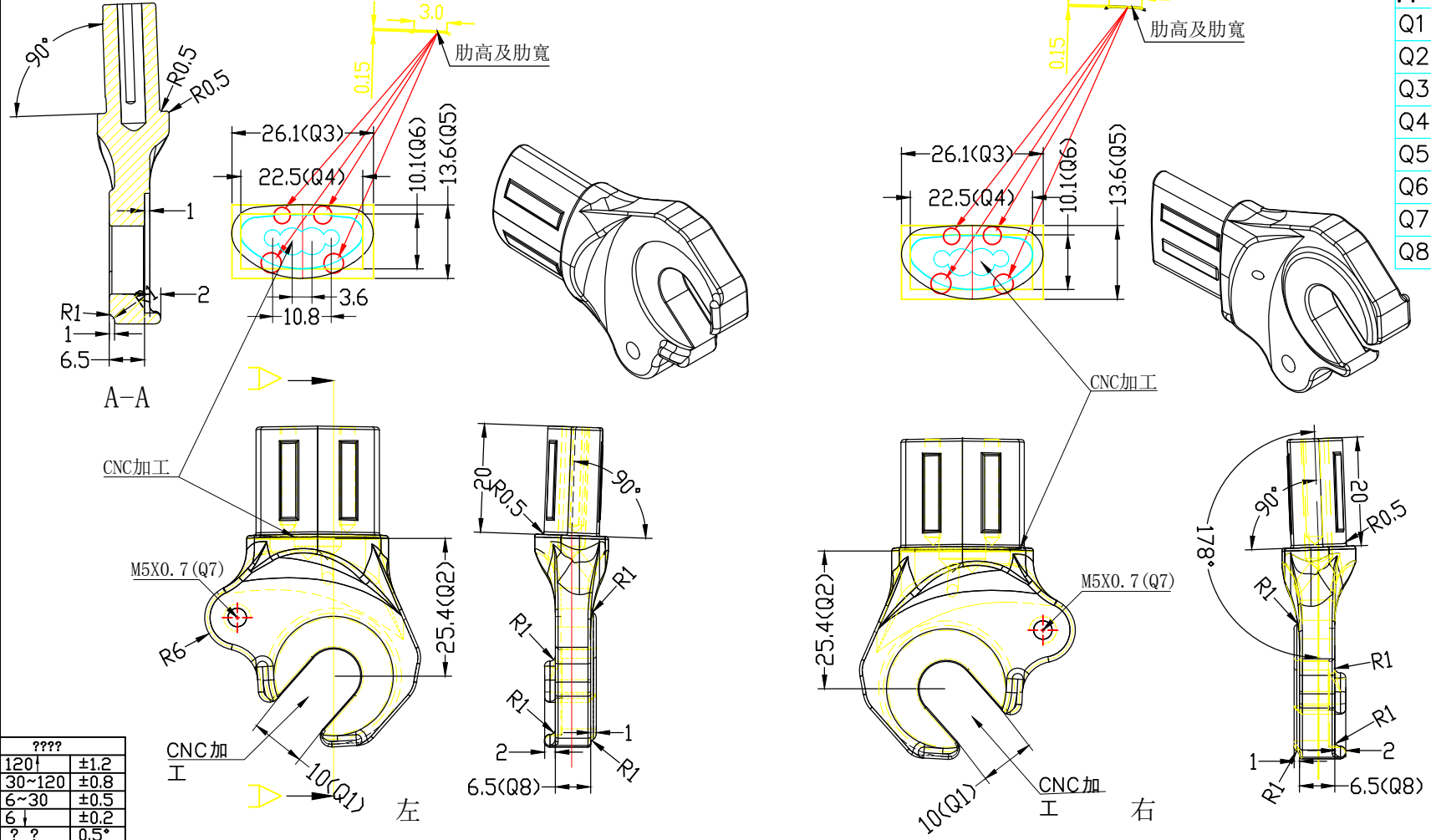

????	???
120↑	±1.2
30~120	±0.8
6~30	±0.5
6↓	±0.2
??	0.5°

PRODUCT ? ? ?	UNIT ? ? ?	MM	DRAWN BY ? ? ?	08.07.14	??	HRB52	??	1 ?	???	◎	△				
RAWING NO. JB-9E-0024	SCALE 1:1		CHECKED BY ? ? ?								△				
CLIENT ? ? ?	MASTER ? ? ?		APPROVED BY ? ? ?								△				
???	23-G105-0??										△				
												SIGN	REVISION	DATE	DESCRIPTION



JIANGDING, HANDWARE MANUFACTURE CO., LTD