

加工流程：鋸料>鍛造>T4/T6>切邊>CNC銑床>研磨>震動>洗白>品管>包裝

加工圖

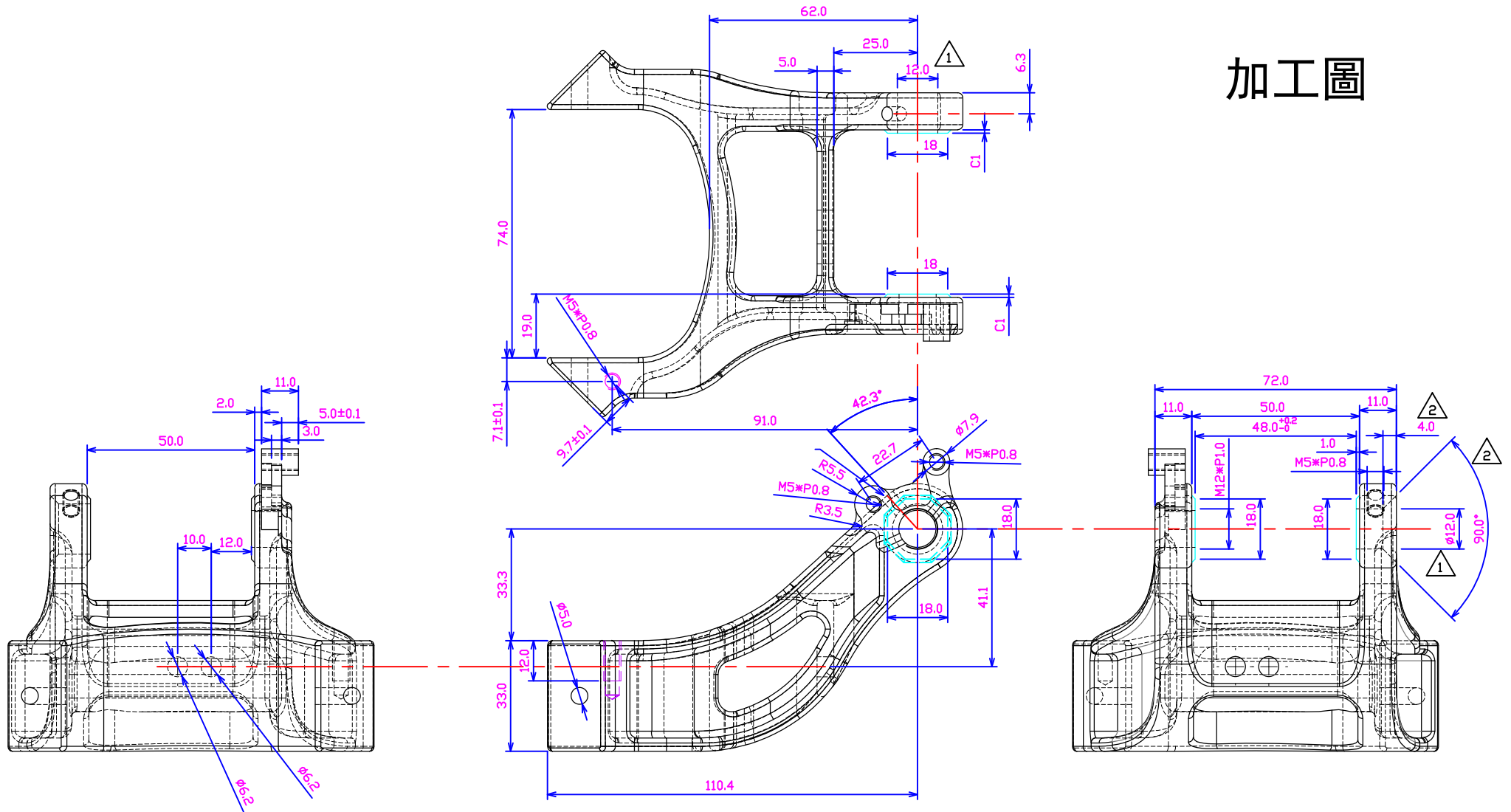

鍛造用料: ?? mm
 PS: 鋁料一米長可切 ?? Piece

- ① 修改為12mm圓孔
- ② 增加4mm深90度倒角

30-A104-01

繪圖 Drawn	Tim	2017.05.12	處理 FINISH		
校對 Checked		材質 Material	AL6061	比例 Scale	
審核 Approved		產品名稱 Product	Yoke	單位 Unit	mm
		製圖編號 Drawing No:	9H-0083-1	版次 Version	
		客戶編號 Customer No:	Wimcycle	A1	
					允許公差 TOLERANCE >1-4 ±0.1 >4-16 ±0.2 >16-63 ±0.3 >63-250 ±0.5 角度公差 ANGULAR ±0.5°